



I AUTODESK® INVENTOR® 2020

Make great products
with professional grade
engineering tools



Deliver innovative products faster

Autodesk® Inventor® software provides professional-grade engineering solutions for 3D mechanical design, simulation, tool creation, and design communication that help you to make great products, cost-effectively, in less time. Inventor is the foundation of the Autodesk solution for product development. The Inventor model is an accurate 3D digital model that enables you to validate the form, fit, and function of a design as you work, minimizing the need to test the design with physical prototypes.

Facing these challenges?

- Increase innovation while reducing time to market
- Repurpose existing DWG™ design data
- Prepare non-native CAD models for new designs
- Optimize product performance while minimizing physical prototypes
- Rapidly create production-ready drawings for manufacturing
- Reduce time spent searching for designs for reuse
- Piping and wiring designs take too long to develop
- Multiple CAD systems for design and manufacturing
- Automate processes to satisfy demands for mass customization

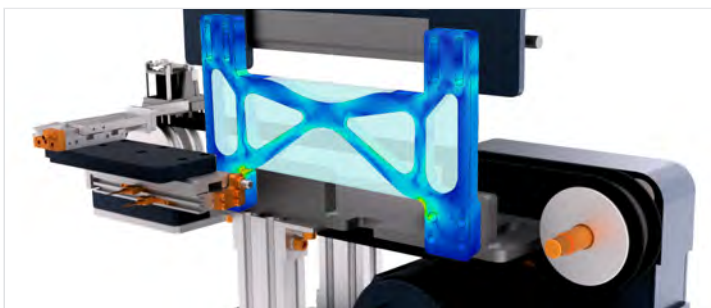
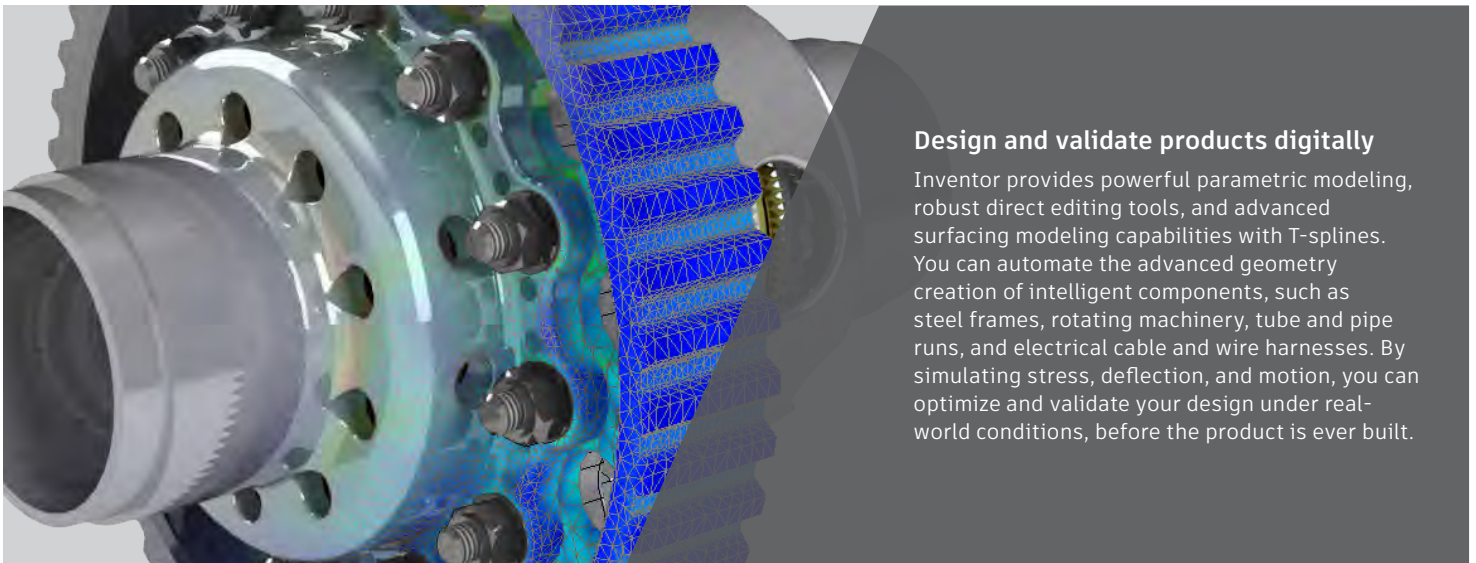

Create the best design possible

Inventor includes topology optimization tools for the optimization and lightweighting of your design. Shape generator provides an intelligent strategy for coming up with the best design possible by removing unnecessary geometry from your model that doesn't contribute to the overall stiffness. It is based on loading conditions and the target weight requirements for your design.



Improve design collaboration and communication

Inventor is tightly integrated with Autodesk® Vault, enabling the efficient and secure exchange of design data and promoting early collaboration between design and manufacturing workgroups. AnyCAD technology enables collaboration in a multi-CAD environment by providing an associative connection with STEP, CATIA, SolidWorks, Siemens NX, Solid Edge, PTC Creo, PTC Wildfire, Autodesk Alias, and AutoCAD 2D directly to Inventor without file translation.

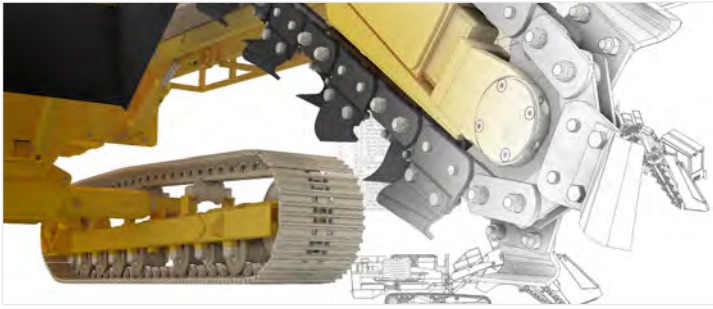

Integrated 2D and 3D design

With Inventor, you can easily integrate AutoCAD® and 3D data into a single digital model to create a virtual representation of the final product. Inventor helps you realize the benefits of 3D product development by providing an associative link to native DWG files that ensures accuracy in your design. Utilizing valuable DWG data with Inventor can help you compete more effectively, service your clients better, and make great products.

10 reasons to choose Inventor

- Shape generator helps to promote the best design possible
- Open and connected workflow for non-native Inventor data
- Flexible modeling tools include parametric and free-form
- Large assembly and drawing performance
- Rules-based design and automation tools to accelerate design

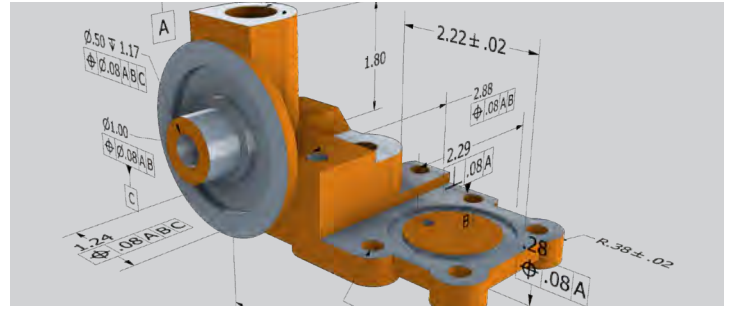

Tools for digital manufacturing

There is a growing demand for engineering organizations to get design data to manufacturing more efficiently. Inventor provides model-based definition for adding all necessary fabrication instruction information directly to the 3D model. This eliminates the need for a traditional 2D drawing used by CNC programmers for tolerances and surface finish on the design.

- Advanced visualization, illustration, and animation tools
- Automated and associative bill of materials
- Robust motion simulation and stress analysis tools
- Design tools for routing rigid pipes, bent tubes, and flexible hoses
- Provide fabrication information directly to your 3D model

“The performance improvements in drawing view creation alone has the potential to save us an astounding 40% or more. This is a significant factor when taking into consideration everything from cost to schedule.”

—Craig Breckenridge
TMT Lead Designer
Dynamic Structures

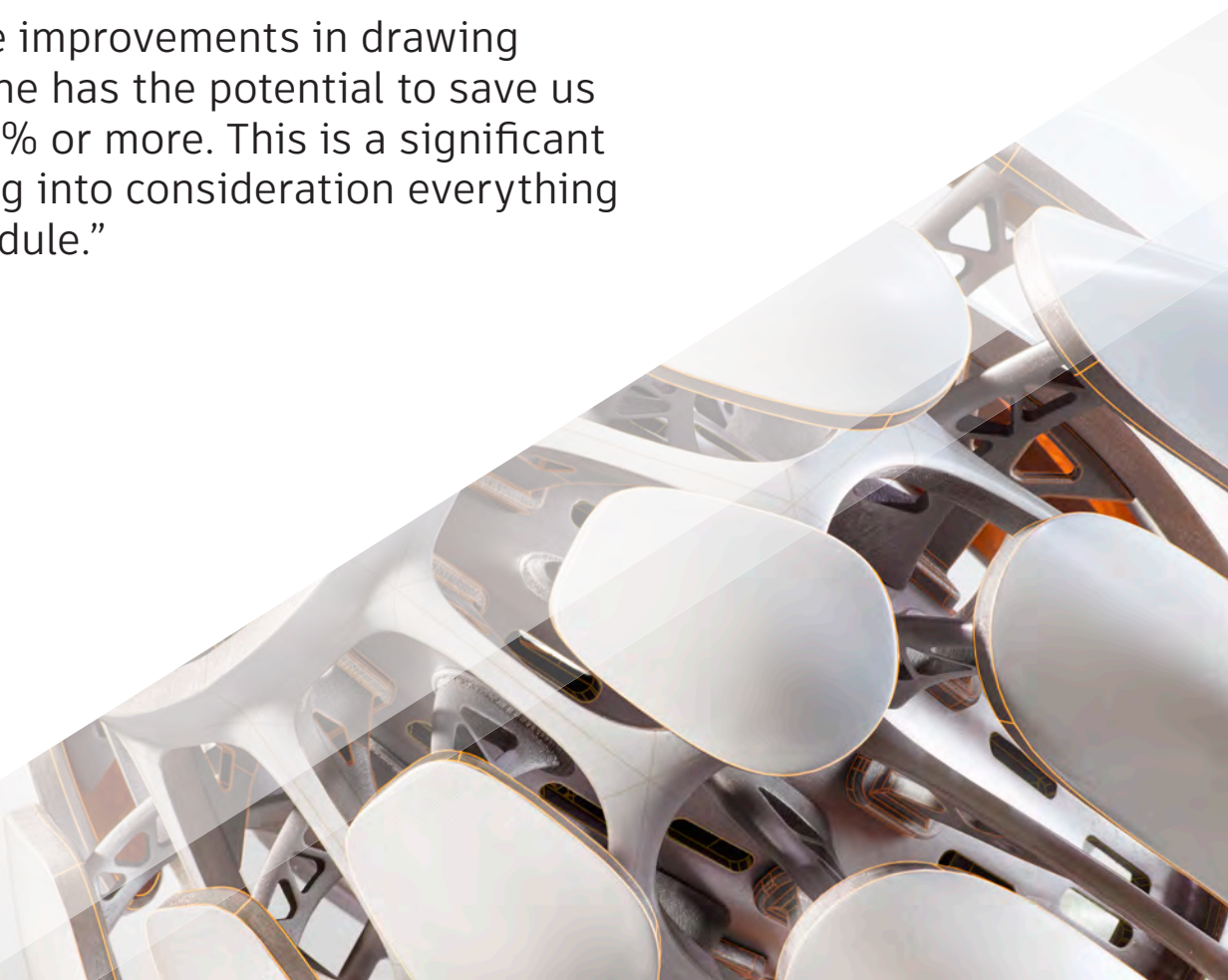

Make Great Products

Autodesk Inventor helps you design better quality products, faster. Accomplish more with Inventor when you connect it with other product design tools in the Product Design and Manufacturing Collection.

- Execute machining strategies with integrated 2.5-axis to 5-axis milling, turning, and mill-turn CAM
- Associatively connect 2D electrical design with 3D mechanical design models
- Plan, design, and validate manufacturing facilities

Autodesk Education

Autodesk offers students and educators a variety of resources to help ensure students are prepared for successful design careers, including access to free* software, curricula, training materials, and other resources.

Autodesk Subscription

Autodesk® Subscription gives you a greater advantage with powerful cloud-based services, access to the latest software, online technical support, and flexible licensing privileges.**

Autodesk Drive

Use CAD-aware cloud storage from Autodesk Drive to securely store, share, and preview any type of design data. Unlike generic cloud storage solutions, Drive is made for CAD, CAM, and BIM—so it can preview 2D or 3D files, manage references, and store 60+ different file types –fitting seamlessly into your workflow.

*Free products are subject to the terms and conditions of the end-user license agreement that accompanies download of this software.

**All Subscription benefits are not available for all products in all geographies.

Autodesk, the Autodesk logo, Alias, AutoCAD, Autodesk Inventor, DWG, Fusion 360, and Moldflow are registered trademarks or trademarks of Autodesk, Inc., and/or its subsidiaries and/or affiliates in the USA and/or other countries. All other brand names, product names, or trademarks belong to their respective holders. Autodesk reserves the right to alter product and services offerings, and specifications and pricing at any time without notice, and is not responsible for typographical or graphical errors that may appear in this document.

© 2019 Autodesk, Inc. All rights reserved.



770.434.3050 • www.reproproducts.com

